

1.5 CHANGE-OVER SYSTEM IN CASE OF ENGINE No. 2

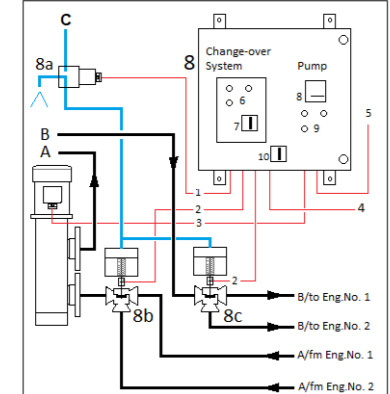

- |    |  |
|----|--|
| 1  | POWER [24V] TO 3-WAY SOL VALVE 8a  |
| 2  | TO POSITION SWITCH OF CYLINDER VALVE 8b/8c   |
| 3  | POWER TO FEED PUMP   |
| 4  | MAIN POWER   |
| 5  | PUMP RUN SIGNAL  |
| 6  | SIGNAL LAMP [Eng. No. 1/2][VALVE 8b/8c FAILURE]  |
| 7  | POSITION SWITCH [ENG-1][ENG-2]<br>*Position ENG-1: S.Lamp No. 1 lights, pump can start<br>*Position ENG-2: S.Lamp No. 2 lights, pump can start<br>!!In case of VALVE FAILURE, pump cannot start or stops |
| 8  | AMP METER FEED PUMP  |
| 9  | PUSH BUTTON/LAMP[START][STOP][FAILURE]   |
| 10 | MAIN SWITCH  |

1.1 SYMBOL

	BALL VALVE		WATER LINE
	GLOBE VALVE		AIR LINE
	FLOW CONTROL VALVE (GLOBE TYPE)		
	TEMP CONTROLLER		ELECTRIC WIRING
	FLOW SWITCH		OIL LINE
	STRAINER		BUTTERFLY VALVE
	COMPOUND GAUGE		PRESSURE GAUGE
	CHECK VALVE		INSULATED
	DRAIN HOPPER		POSITION SWITCH

1.1b SYMBOL // MKK SUPPLY

	SENSOR		SENSOR-CONNECTOR WITH CABLES TO M.M.
--	--------	--	--------------------------------------

1.2 EQUIPMENT

No	Name	Maker	Qty	Remarks
1	OIL PURIFIER	MKK		
1a	CONTROL PANEL	MKK		
1b	MOTOR	MKK		
2	OPERATING WATER UNIT	MKK		24V, BUILD-ON PURIFIER
3	FEED VALVE	MKK		3WAY CYLINDER VALVE
4	3WAY SOL VALVE	MKK		24V
5	MULTI MONITOR	MKK		BUILD-ON PURIFIER
6	FEED PUMP SCREW TYPE	not MKK		LOOSE
7	OIL HEATER ELECTRIC	not MKK		INCL. ACCESSORIES
8	CHANGE -OVER SYSTEM	not MKK		
8a	3WAY SOL VALVE	not MKK		24V
8b	3WAY CYLINDER VALVE	not MKK		
8c	3WAY CYLINDER VALVE	not MKK		
9	GROUP STARTER [1]	not MKK		E-MOTOR 1XHEATER
9a	GROUP STARTER [2]	not MKK		EQL AS 9 + PUMP RUNNING
10	JUNCTION BOX	not MKK		

1.3 CONNECTIONS

Letter	Description	Pressure	Source
A	DIRTY OIL INLET		LO FROM SUMP TANK
B	PURIFIED OIL OUTLET		LO TO SUMP TANK
C	COMPRESSED AIR INLET	0.5~0.7 MPa	
D	SLUDGE&WATER OUTLET		TO SLUDGE TANK
E	WATER INLET	0.35~0.50 MPa	
F	OPERATING WTR DRAIN		TO SLUDGE TANK
G	CIRCULATION		LO TO SUMP TANK
P	POWER SUPPLY		FROM SHIP

1.4 PROJECT DETAILS

PROJECT/No.	
SYSTEM	LO Mitsubishi Separator for AUX/ENG No. 1&2
DRAWING/No.	MKK EUROPE B.V. / W.V.